

HGEN Series

Refrigerated Type Compressed Air Dryers

Models: HGEN600, HGEN800, HGEN1000, HGEN1200

FORM NO.: 7426448 REVISION: 10/2018

READ AND UNDERSTAND THIS MANUAL PRIOR TO OPERATING OR SERVICING THIS PRODUCT.



Contents

GENERAL SAFETY INFORMATION	1
RECEIVING, MOVING, AND UNPACKING	1
INSTALLATION	2
INSTRUMENTATION	3
START-UP/OPERATION.....	4
SHUTDOWN.....	4
MAINTENANCE.....	5
FIELD SERVICE GUIDE.....	6
SPECIFICATIONS	
ENGINEERING DATA TABLE.....	7
AIR-COOLED UNITS	
General Arrangement Drawings	
Model HGEN600A	8
Model HGEN800A	9
Models HGEN1000A through HGEN1200A.....	10
Electrical Schematics	
Model HGEN600A	11
Models HGEN800A through HGEN1200A.....	12
Air and Refrigerant Flow Schematics	
Model HGEN600A	13
Models HGEN800A through HGEN1200A.....	14
WATER-COOLED UNITS	
General Arrangement Drawings	
Model HGEN600W	15
Model HGEN800W	16
Models HGEN1000W through HGEN1200W.....	17
Electrical Schematics	
Model HGEN600W	18
Models HGEN800W through HGEN1200W.....	19
Air and Refrigerant Flow Schematics	
Model HGEN600W	20
Models HGEN800W through HGEN1200W.....	21
REPLACEMENT PARTS.....	22
NOTES.....	23
WARRANTY	25

GENERAL SAFETY INFORMATION**1. PRESSURIZED DEVICES:**

This equipment is a pressure containing device.



- Do not exceed maximum operating pressure as shown on equipment serial number tag.
- Make sure equipment is depressurized before working on or disassembling it for service.

2. ELECTRICAL:

This equipment requires electricity to operate.



- Install equipment in compliance with all applicable electrical codes.
- Standard equipment is supplied with electrical enclosures not intended for installation in hazardous environments.
- Disconnect power supply to equipment when performing any electrical service work.

3. BREATHING AIR:

- Air treated by this equipment may not be suitable for breathing without further purification.

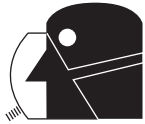

Refer to applicable standards and specifications for the requirements for breathing quality air.

RECEIVING, MOVING, AND UNPACKING**A. RECEIVING**

This shipment has been thoroughly checked, packed and inspected before leaving our plant. It was received in good condition by the carrier and was so acknowledged.

To assure proper transport, tilt indicators are attached to the shipping container before it leaves the factory. Check these before accepting unit from carrier's agent.

Check for Visible Loss or Damage. If this shipment shows evidence of loss or damage at time of delivery to you, insist that a notation of this loss or damage be made on the delivery receipt by the carrier's agent.

B. UNPACKING

Check for concealed loss or damage. When a shipment has been delivered to you in apparent good order, but concealed damage is found upon unpacking, notify the carrier immediately and insist on his agent inspecting the shipment. Concealed damage claims are not our responsibility as our terms are F.O.B. point of shipment.

C. MOVING

In moving or transporting dryer, do not tip dryer onto its side.

D. STORAGE

CAUTION Dryer should not be stored outside (either packed or unpacked) or exposed to the weather. Damage to electrical and control components may result.

IMPORTANT: WATER-COOLED UNITS - If unit is shut down in below freezing temperatures, the water-cooled condenser may freeze and cause permanent damage. Condenser must be drained when unit is shut down.

IMPORTANT: Do not store dryer in temperatures above 130°F (54.4°C).

INSTALLATION

Ambient Air Temperature

Locate the dryer indoors where the ambient air temperature will be between 40°F (4°C) and 110°F (43°C). Intermittent operation at ambient temperatures up to 113°F (45°C) will not damage the dryer but may result in a higher dew point or dryer shutdown due to high refrigerant discharge pressure (see Field Service Guide).

Do not operate dryers at ambient air temperatures below 40°F (4°C). Such operation may result in low suction pressure, causing freeze-up.

Location and Clearance

Mount the dryer on a level solid surface. Holes are provided in the dryer base to permanently mount the dryer to the floor. If the base vibrates, bolt the unit down using vibration dampeners. Allow at least 36 inches (914 mm) clearance on the sides and the front of the dryer for cooling airflow and for service access.

System Arrangement

Liquid water in the inlet air will adversely affect the performance of the dryer. Install the dryer downstream of an aftercooler or separator so that the temperature of the dryer inlet air does not exceed 120°F (49°C) and the inlet air does not contain any liquid water.

If the compressed airflow is relatively constant and does not exceed the dryer flow rating, it is recommended that the dryer be located downstream of the receiver tank. If the nature of the application is such that the air demand regularly exceeds the dryer flow rating, it is recommended that the dryer be located upstream of the receiver.

For safety and convenience, install inlet and outlet shutoff valves and depressurization valves. These valves allow the dryer to be isolated and depressurized for servicing. Bypass piping may be installed around the dryer for uninterrupted airflow when the dryer is serviced. If the compressed air operation cannot tolerate undried air for short periods, install a second dryer in the bypass line.

Compressed air systems commonly require filters to remove compressor oils, particulates, condensed liquids and other contaminants. When an oil-removal filter is used, it should be installed downstream of the refrigerated dryer. At this location, the life of the replaceable filter element is prolonged since some of the entrained oil is removed by the dryer and drained through the separator.

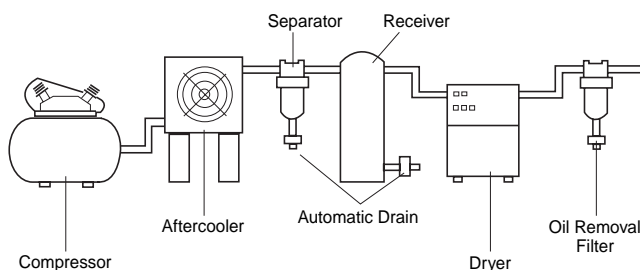

TYPICAL COMPRESSED AIR SYSTEM

Piping and Connections

Piping must be furnished by the user unless otherwise specified. Connections and fittings must be rated for the maximum operating pressure given on the dryer data plate and must be in accordance with applicable codes. Support all piping; do not allow the weight of any piping to stress the dryer or filter connections. Piping should be at least the size of the inlet and outlet connections to minimize pressure drop in the air system. See Engineering Data section for dryer inlet and outlet connections

1. Air Inlet - Connect compressed air line from air source to air inlet.

WARNING Refer to Serial Number Tag for maximum working pressure. Do not exceed dryer's Maximum Working Pressure.

NOTE: Install air dryer in air system at highest pressure possible (e.g. before pressure reducing valves).

NOTE: Install dryer at coolest compressed air temperature possible. Maximum inlet compressed air temperature: 120°F (49°C). If inlet air exceeds this temperature, precool the air with an aftercooler.

2. Air Outlet - Connect air outlet to downstream air lines.
3. Bypass Piping - If servicing the dryer with interrupting the air supply is desired, piping should include inlet and outlet valves and an air bypass valve.
4. Water-cooled models - cooling water inlet and outlet.
 - a) Connect cooling water supply to cooling water inlet.
 - b) Connect cooling water return line to cooling water outlet connection.

NOTE: Strainer and water regulating valve are supplied on water-cooled models. Also, it is recommended to add water inlet/outlet temperature and pressure gauges to the water piping.

Removing Condensate

Condensate must be drained from the dryer to prevent re-entrainment. The dryers are equipped with automatic drain valves and internal drain hoses up to the drain connections on the dryer cabinets. The user must install a separate discharge line at the drain connection to carry off condensate to an environmentally approved condensate collection/disposal system. Piping or copper tubing 1/2 inch or larger is recommended for condensate discharge lines. Install the drain lines so that condensate can be seen as it drains.

Electrical Connections

The dryers are constructed according to NEMA Type 1 electrical standards. Field wiring must comply with local and national fire, safety and electrical codes. Installation must be in accordance with the National Electrical Code.

IMPORTANT: Use copper supply wires only.

1. Dryer is designed to operate on the voltage, phase, and frequency listed on the dryer serial number tag.
2. Electrical entry is through a hole in the back of the cabinet. Route wires through the bottom of the electrical enclosure. Connect power source to the terminal strip in the electrical enclosure as shown on the electrical schematics included in this manual.

NOTE: Refrigeration condensing unit is designed to run continuously and should NOT be wired to cycle on/off with the air compressor.

CAUTION Operation of dryers with improper line voltage constitutes abuse and could affect the dryer warranty.

INSTRUMENTATION

ON/OFF Switch

The dryer is equipped with an ON/OFF switch on the front panel. A light signals when the dryer is on.

Dryer System Monitor (DSM)

The Dryer System Monitor (DSM) has LED type dew point temperature indicator and operating time control for the electronic drain valve. When the dryer is running normally, the green LED will illuminate. If the red LED is illuminated, there is a need for the dryer's operating condition to be checked. If all LEDs are illuminated, the sensor for the dew point temperature indicator has malfunctioned.

The automatic drain valve controls allow the period of drain opening to be set from 1 second to 9 seconds and drain valve closed time to be set from 0.5 minutes to 15 minutes. When the Drain Push-to-Test button (5) is pushed for one (1) second, the Drain LED (6) will illuminate and the drain port opens with a click.

Automatic Drain Valve

All models are equipped with an electronic drain valve that automatically discharges condensate from the dryer. Drain valve operation is controlled by a drain valve timer. The drain opening can be set from 0.5 seconds to 9 seconds. The drain cycle can be set from 0.5 minutes to 15 minutes.

Drain valve adjustments are made on the Dryer System Monitor:

1. Press the Selection (4) and Enter (5) buttons at the same time for 3 seconds, the On Time Setting Mode LED (3) will start to blink, and the illuminated LED on the Dew Point Temperature Indicator LED (2) will identify the factory setting for "On Time". (See table)
2. Press and release the Selection button (4) to sequence from left to right until reaching your selection. The red LED is not used.
3. To store the "On Time", press the Enter button (5) and set the "Off Time" using step 2.
4. To store the "Off Time", press the Enter button (5) again.
5. Exiting the Program will cause the Timer Drain to discharge and begin a new cycle.

NOTE: Failure to perform step 3 within 10 seconds of completing step 2 will cause the unit to revert back to the previous setting.

LED (2) Position	1st	2nd	3rd	4th	5th	6th	7th	8th	9th
On Time (sec)	1	2	3	4	5	6	7	8	Continuous (Drain Trap Option)
Off Time (min)	0.5	1	2	3	5	7	9	10	15

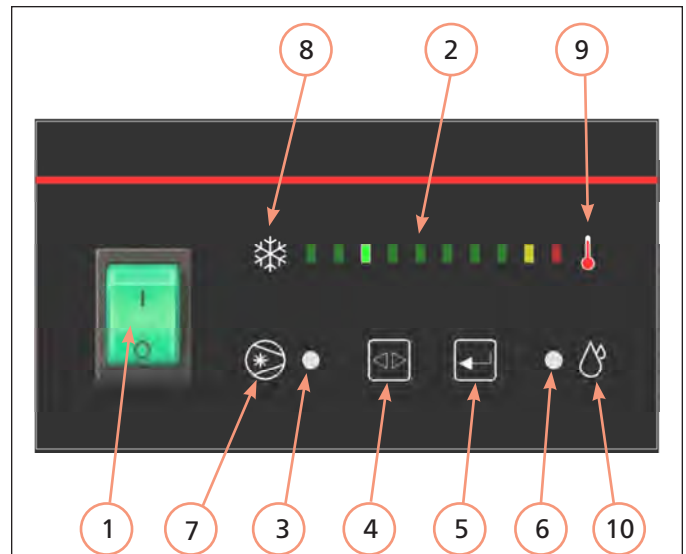

Dryer System Monitor

1. On/Off Switch: Press the top of the switch (I) to turn the dryer on. Press the bottom of the switch (O) to turn the dryer off. When the dryer is on, the switch is illuminated.
2. Dew Point Temperature Indicator: Main portion of the graphic for the dew point temperature scale. Green indicates low, red indicates high.
3. Compressor On Light / On Time Setting Mode: Dual purpose LED indicating light. Illuminates as solid light when compressor is ON. Blinks On and Off during setup of the On Time Set Points for the Automatic Drain Valve.
4. Selection Button: During set up of the Automatic Drain Valve, when pressed, sequences from left to right.
5. Drain Push-to-Test Button / Enter Button:
 - a) Drain Push-to-Test button. When the button is pressed, the drain valve opens for the time corresponding to the setting established during Drain Valve setup.
 - b) Enter button. Stores the "On Time" and "off Time" drain valve settings established during Drain Valve setup
6. Drain LED / Off Time Setting Mode: Dual purpose LED indicating light. Illuminates as solid light when Drain is closed. Blinks On and Off during setup of the Off Time Set Points for the Automatic Drain Valve.
7. This is a graphic symbol for the Air Dryer compressor. It simply indicates that the switch is used to turn the compressor (dryer) on and off.
8. Part of the graphic for the dew point temperature scale. The snowflake indicates the low (cold) end of the scale.
9. Part of the graphic for the dew point temperature scale. The thermometer indicates the high (hot) end of the scale.
10. This is a graphic symbol for the Drain Valve.

Electronic Drain Valve Adjustment

The automatic drain valve has been pre-programmed at the factory for your specific HGEN Series dryer. Programming is based upon a minimum of 100 psi saturated inlet air pressure and maximum energy efficiency. Generally no adjustment to the timer is necessary.

▲ CAUTION If water is present downstream of the dryer, always verify that and condensate drains installed upstream of the dryer are draining properly before attempting to adjust the timer settings.

1. For minimum inlet air pressures that fall between column values the setting for the lower pressure is recommended. (i.e. select the 100 psi column values for 124 psi inlet pressure.)
2. Where the dryer is consistently operating at less than maximum capacity, it may be possible to alter the timer set points to minimize air loss. Discretionary adjustments to the dryer should only be made on a hot, humid day when the maximum expected air load is flowing through the dryer. Failure to do so may prevent the condensate from draining completely when operating under peak load conditions.

Dryer Model	Inlet Pressure (psig)											
	75		100*		125		150		200		225	
	On	Off	On	Off	On	Off	On	Off	On	Off	On	Off
	(sec)	(min)	(sec)	(min)	(sec)	(min)	(sec)	(min)	(sec)	(min)	(sec)	(min)
HGEN600	2	1	2	1	2	2	2	3	2	5	2	6
HGEN800	2	2	2	2	2	3	2	5	2	8	2	8
HGEN1000	2	2	2	2	2	3	2	4	2	6	2	8
HGEN1200	2	1	2	1	2	2	2	3	2	5	2	6

* Recommended and pre-programmed factory settings for each HGEN Series model dryer.

Assumes dryer operates at ISO 7183 (Option A2) conditions: 100°F inlet air temperature, 100 psig operating pressure, 100°F ambient air temperature and 10°F air-cooled after-cooler approach temperature.

START-UP/OPERATION

Follow the procedure below to start your dryer. Failure to follow the prescribed start-up procedure will invalidate the warranty. If problems arise during start-up, call your distributor.

▲ WARNING Refer to Serial Number Tag for dryer operating capacity. Do not exceed recommended capacity.

Drain connections must be made before the dryer can be operated. The dryers are fully automatic and require no auxiliary controls.

1. Turn the dryer ON/OFF switch to OFF.
2. Check that the main electrical supply voltage matches the voltage specified on the dryer data plate.
3. Check proper connection and support of compressed air lines to the dryer; check bypass valve system, if installed.
4. **Energize Dryer:** Turn disconnect switch to "ON" position. Green dryer ON/OFF switch will illuminate.

▲ WARNING Energize dryer for 24 hours before refrigeration compressor is started! Never use the disconnect switch to shutdown the dryer for an extended period of time (except for repair). Failure to follow these instructions may result in a non-warrantable compressor failure.

5. Ensure adequate ventilation for air-cooled dryers.
6. On water-cooled models, before starting dryer, begin cooling water flow.

To start dryer:

1. Turn the power switch to ON. The refrigerant compressor will turn on.
 - ▲ WARNING** Dryer must be energized 24 hours before starting refrigeration compressor.
2. Allow the dryer to run 15 minutes. Confirm that the temperature indicators are in the green zone.
3. SLOWLY pressurize the dryer. The outlet valves of the dryer should be closed to prevent flow through the dryer.
4. SLOWLY open the dryer outlet valves permitting flow through the dryer.
5. Confirm that condensate is discharging from the drain valve by pressing the "Push-to Test" button.
6. Check drain valve timing. See Automatic Drain Valve section for drain valve adjustment procedure.
7. Confirm that the inlet air temperature, pressure and airflow to the dryer meet the specified requirements (see Engineering Data section).
8. Confirm that the condensate lines from the drain valve discharge into a collection tank or an environmentally-approved disposal system.

The dryer is designed to run continuously. Let the dryer run even when the demand for compressed air is interrupted; the dryer will not freeze up.

SHUTDOWN

When the dryer must be shutdown for maintenance or other reasons, use the following procedure.

If electrical repairs must be made:

1. Turn off the power switch.
2. Disconnect the main power supply.
3. Lock out and tag the power supply in accordance with OSHA requirements.

If mechanical repairs are to be made or service is performed, vent the internal pressure of the dryer to atmospheric pressure. Restart the dryer according to the start-up instructions.

▲ WARNING Disconnect power supply and depressurize dryer before servicing. Dismantling or working on any component of the compressed air system under pressure may cause equipment failure and serious personal injury.

MAINTENANCE

The dryers require little maintenance for satisfactory operation. Good dryer performance can be expected if the following routine maintenance steps are taken.

⚠ WARNING Dismantling or working on any component of the compressed air system under pressure may cause equipment failure and serious personal injury. Before dismantling any part of the dryer or compressed air system, completely vent the internal pressure to the atmosphere.

General

For continued good performance of your refrigerated dryer, all refrigeration system maintenance should be performed by a competent refrigeration mechanic.

NOTE: Before corrective maintenance is done during the warranty period, call your local distributor and proceed according to instructions. Refer to the warranty for limits of your coverage.

Daily Maintenance

Check the operation of the automatic drain valve at least once daily. See the Field Service Guide for remedies to drain valve malfunctions. See the AUTOMATIC DRAIN VALVE section for drain valve adjustment.

Monthly Maintenance

For air-cooled models, it is recommended to inspect the condenser coils monthly. If necessary, remove dirt or other particles with compressed air from an OSHA-approved air nozzle that limits its discharge pressure to 30 psig (2.1 kgf/cm²).

For water-cooled models, clean strainer monthly, more often if required. Shut off water, remove small plug to relieve pressure, then remove large plug to remove strainer. Clean strainer and replace.

Electronic Drain Valve Disassembly and Servicing

The valve body is attached to the valve strainer which is attached to the heat exchanger vessel.

⚠ CAUTION Do not disassemble drain valve timer or attempt to repair electrical parts. Replace timer if defective.

The drain valve discharge condensate through a full-port drain opening. The valve body may need to be cleaned under conditions of gross particulate contamination.

To disassemble the drain valve body for cleaning and other maintenance:

1. Turn power switch off.
2. Disconnect main power supply to dryer.
3. Depressurize unit.
4. Lock out and tag power supply in accordance with OSHA requirements.

⚠ WARNING If power supply is not connected and unit is not depressurized before disassembly, serious personal injury and valve damage may result.

5. Removes hoses that connect the drain valve to the drain discharge fitting and remove the valve from the drain valve strainer.
6. Remove screw and washer from front of the drain valve.
7. Remove the power supply connector and gasket (with the timer assembly if attached) from the solenoid coil housing. Do not damage or lose the gasket.
8. Remove coil fixing nut from top of solenoid coil housing.
9. Lift solenoid coil housing off solenoid core in valve body.
10. Unscrew solenoid core from valve body.

Once the drain valve is disassembled, the following maintenance can be performed.

1. Inspect internal parts of valve body; clean or replace as required.
- NOTE:** Replace solenoid valve if component damage is observed.
2. Remove debris from valve body.
 3. Wipe solenoid core components with a clean cloth or blow out debris with compressed air from an OSHA-approved air nozzle that limits its discharge pressure to 30 psig.
 4. Check that the plunger assembly is clean and moves freely in housing.
 5. If timer is attached to valve body, check electrical continuity across timer assembly.

To reassemble the drain valve, reverse the sequence of the preceding steps. After the drain valve is reassembled, connect the main power supply to the dryer.

When the dryer is returned to service, check the drain valve for air or condensate leaks; tighten connections as required to correct leaks. Check the drain cycle; adjust the timer according to the procedure in the drain valve adjustment section.

FIELD SERVICE GUIDE

Problems most frequently encountered with refrigerated dryers are water downstream of the dryer and excessive pressure drop. Most causes can be identified and remedied by following this guide.

⚠ WARNING Closed refrigeration systems are potentially dangerous. Work on the refrigeration system must be done only by a competent licensed refrigeration mechanic. Do not release fluorocarbon refrigerants to the atmosphere. Do not discharge liquid refrigerants into floor drains. Refrigerant vapors may accumulate in low places. Inhalation of high concentrations may be fatal. All refrigerants must be recovered per EPA requirements.

Do not smoke when a refrigeration leak is suspected. Burning materials may decompose refrigerants, forming a toxic gas or acids that may cause serious injury and property damage.

Before dismantling any part of the dryer or compressed air system, completely vent the internal pressure to the atmosphere.

PROBLEM	SYMPTOM	POSSIBLE CAUSE	REMEDY
Water Downstream of Dryer	Refrigerant compressor not running.	Loss of power to dryer	Check power supply, fuses and/or breakers. Check for loose connections.
		Dryer turned off.	Check On/Off switch position.
		Dryer overloaded.	Confirm that inlet flow, inlet temperature and inlet pressure are within acceptable range of dryer.
		Condenser clogged with debris.	Check/clean condenser.
		Fan motor inoperative	Check fan motor operation. Replace if necessary.
		Ambient temperature too high.	Verify ambient temperature throughout day.
		High pressure switch activated	Press manual reset button to switch to reset button.
		Compressor overheated.	Turn dryer off. Contact local distributor.
	Compressor defective.	Turn dryer off. Contact local distributor.	
	No condensate discharging from dryer.	Drain strainer clogged.	Clean drain strainer.
		Drain valve inoperative.	Check/rebuild drain valve.
		Drain timer or DSM inoperative.	Confirm there is power to the timer or DSM. Replace timer or DSM, if necessary.
		Drain solenoid inoperative.	Confirm there is power to the coil. Replace coil, if necessary.
Condensate discharging from dryer.	Incorrect drain timer setting.	Adjust drain timer - increase open time and/or decrease closed time.	
Liquid water entering dryer.	Aftercooler drain valve malfunction.	Check, repair aftercooler drain valve.	
Excessive Pressure Drop Across Dryer	Frozen condensate in evaporator.	Incorrect constant pressure valve setting.	Contact local distributor.
	Inlet air pressure low.	Upstream restriction in air system.	Check all upstream air system components (valves, regulators, etc.)
	Dryer undersized.	Excessive compressed air flow.	Resize dryer.
Dew Point Indicator Out of Green Zone	Dew Point Indicator Out of Green Zone	Dryer overloaded.	Confirm that inlet flow, inlet temperature and inlet pressure are within acceptable range of dryer.
		Condenser clogged with debris.	Check/clean condenser.
		Loose sensor connection.	Confirm gauge or DSM sensor is tightly connected to dryer tubing.
		Defective gauge, DSM or DSM sensor.	Replace gauge, DSM or DSM sensor.

SPECIFICATIONS: ENGINEERING DATA TABLE

Model		HGEN600	HGEN800	HGEN1000	HGEN1200	
Air System Data						
Rated Air Flow at 100°F & 100 psig Inlet, 100°F Ambient (scfm)	60 Hz	600	800	1000	1200	
Minimum / Maximum Inlet Compressed Air Pressure		43.5 / 232 psig (3 / 16 barg)				
Minimum / Maximum Inlet Compressed Air Temperature		45° / 120°F (7° / 49°C)				
Minimum / Maximum Ambient Temperature		37° / 109°F (3° / 43°C)				
Outlet Air Temperature (nominal at rated conditions)		86°F (30°C)				
Refrigeration System Data						
Compressor Type		Hermetic Reciprocating				
Refrigeration Compressor Horsepower		3 US RT	4 US RT	5 US RT	6 US RT	
Refrigeration Capacity @ Rated Flow (BTU/hr)*		60 Hz	34,080	48,120	60,380	76,870
Refrigerant Type		R-407C				
Refrigerant Charge		See Data Tag on Dryer				
Suction Pressure Setting		60 psig (4.1 barg)				
Compressor Pressure Switch Setting (cut out / cut in)		High, a-c	398 psig / manual reset (27.4 barg / manual reset)			
		High, w-c	313 psig / manual reset (21.6 barg / manual reset)			
Air-Cooled Condensers						
Air Flow Across Condenser (cfm)		60 Hz	2,825	4,120	4,120	4,120
Condenser Fan Switch Setting (cut in / cut out)		Fan 1 / Fan 2	299 / 213 psig (20.6 / 14.7 barg)			
Water-Cooled Condensers						
Water Regulating Valve Setting		220 psig (15.2 barg)				
Minimum Water Pressure Differential		40 psig (2.8 barg)				
Cooling Water Flow with 85°F (gpm)*		60 Hz	6.15	8.19	10.24	12.29
Electrical Data						
Nominal Voltage		460/3/60				
Voltage Range		414 - 506				
Input Power @ Rated Flow (watts) *		3,800	5,400	6,600	8,660	
Minimum Circuit Ampacity		7.8	10.1	12.6	15.9	
Maximum Overcurrent Protector (amps)		15	20	20	25	
Compressor Rated Load Amps		5.7	7.3	9.4	12.0	
Compressor Locked Rotor Amps		30	42	67	80	

NOTES

* 60 Hz: 35°F Evaporator & 100°F Ambient; 50 Hz: 35°F Evaporator & 77°F Ambient

SPECIFICATIONS: AIR-COOLED UNITS

General Arrangement Drawing:
Model HGEN600A

MODEL	DIMENSIONS, INCHES (MM)											INLET/OUTLET CONNECTIONS	WEIGHT Lb. (kg)
	A	B	C	D	E	F	G	H	J	K	L		
HGEN600A	31.94 (811.2)	21.75 (552.4)	50.44 (1281.3)	4.86 (123.5)	7.94 (201.6)	3.23 (82.0)	26.74 (679.2)	20.24 (514)	4.18 (106.2)	40.94 (1040)	49.26 (1251.2)	2" NPT	344 (156)

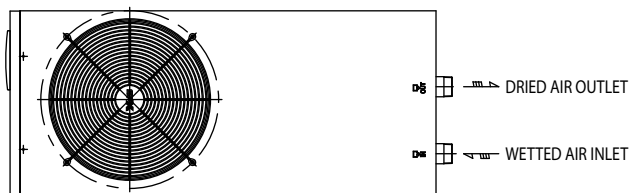

TOP VIEW

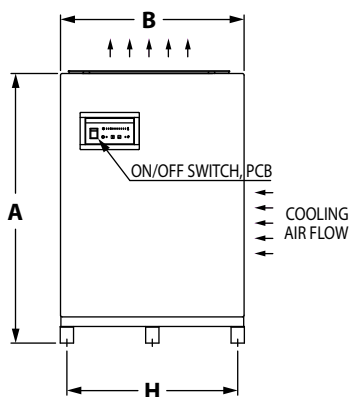

FRONT VIEW

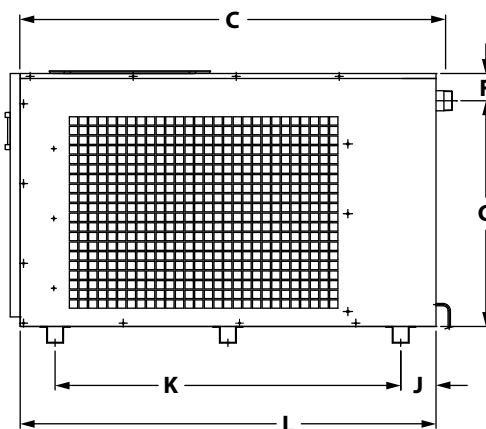

RIGHT SIDE VIEW

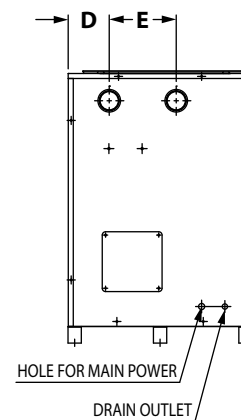

REAR VIEW

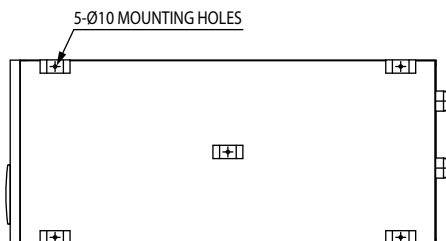

FOOT PRINT

SPECIFICATIONS: AIR-COOLED UNITS

General Arrangement Drawing:
Model HGEN800A

MODEL	DIMENSIONS, INCHES (MM)											INLET/OUTLET CONNECTIONS	WEIGHT Lb. (kg)
	A	B	C	D	E	F	G	H	J	K	L		
HGEN800A	31.10 (790)	21.10 (536)	10.00 (254)	26.77 (680)	28.35 (720)	37.40 (950)	41.34 (1050)	59.83 (1519.6)	35.22 (894.5)	6.12 (155.5)	3.35 (85)	3" ANSI Flange	695 (315)

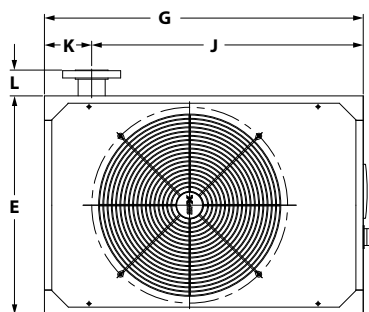

TOP VIEW

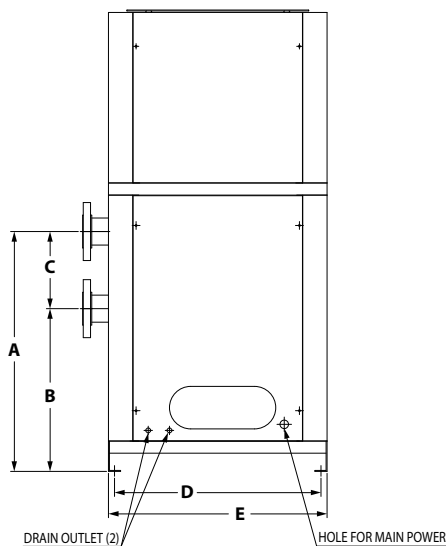

REAR VIEW

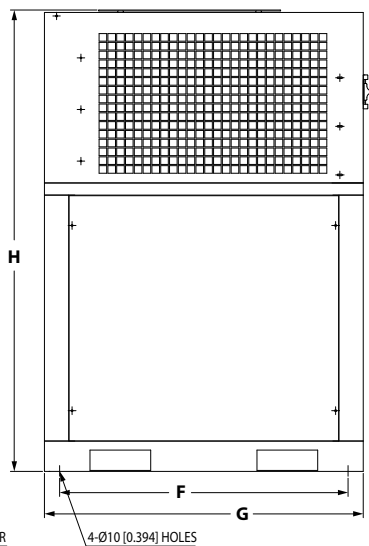

LEFT SIDE VIEW

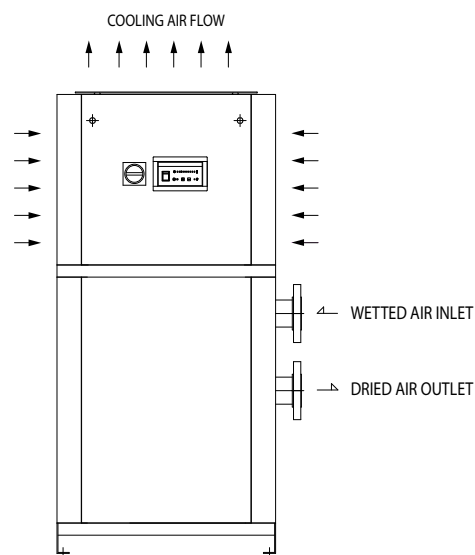

FRONT VIEW

SPECIFICATIONS: AIR-COOLED UNITS

General Arrangement Drawing:
Models HGEN1000A through HGEN1200A

MODEL	DIMENSIONS, INCHES (MM)											INLET/OUTLET CONNECTIONS	WEIGHT Lb. (kg)
	A	B	C	D	E	F	G	H	J	K	L		
HGEN1000A	31.60 (802.7)	20.60 (523.3)	11.00 (279.4)	26.77 (680)	28.35 (720)	41.34 (1050)	45.28 (1150)	64.16 (1629.6)	38.68 (982.5)	6.59 (167.5)	3.35 (85)	4" ANSI Flange	744 (337)
HGEN1200A	31.60 (802.7)	20.60 (523.3)	11.00 (279.4)	26.77 (680)	28.35 (720)	41.34 (1050)	45.28 (1150)	64.16 (1629.6)	38.68 (982.5)	6.59 (167.5)	3.35 (85)	4" ANSI Flange	816 (370)

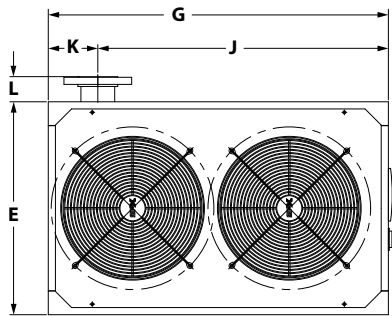

TOP VIEW

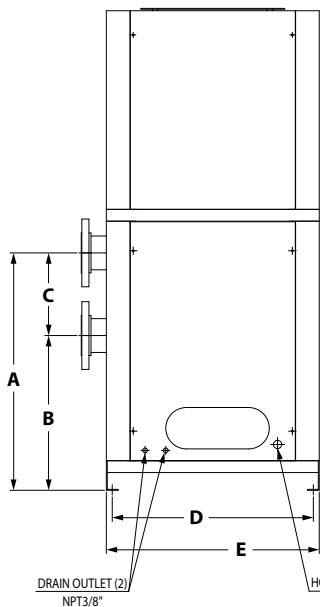

REAR VIEW

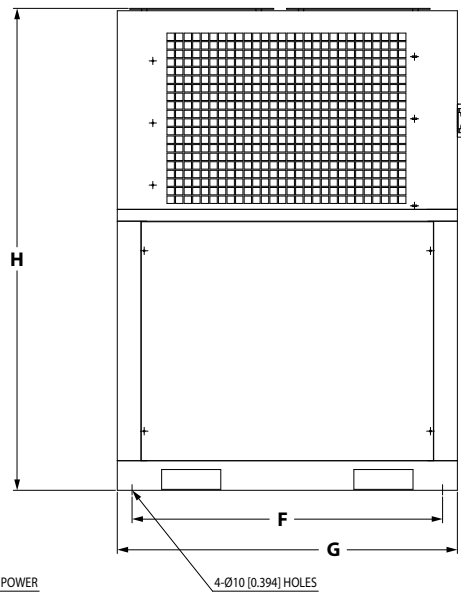

LEFT SIDE VIEW

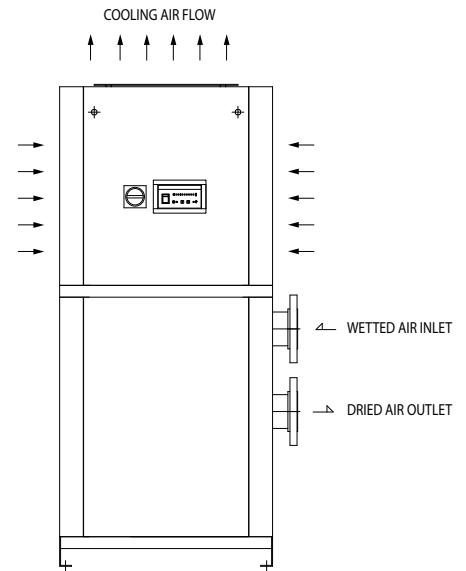

FRONT VIEW

SPECIFICATIONS: AIR-COOLED UNITS

Electrical Schematic:
Model HGEN600A

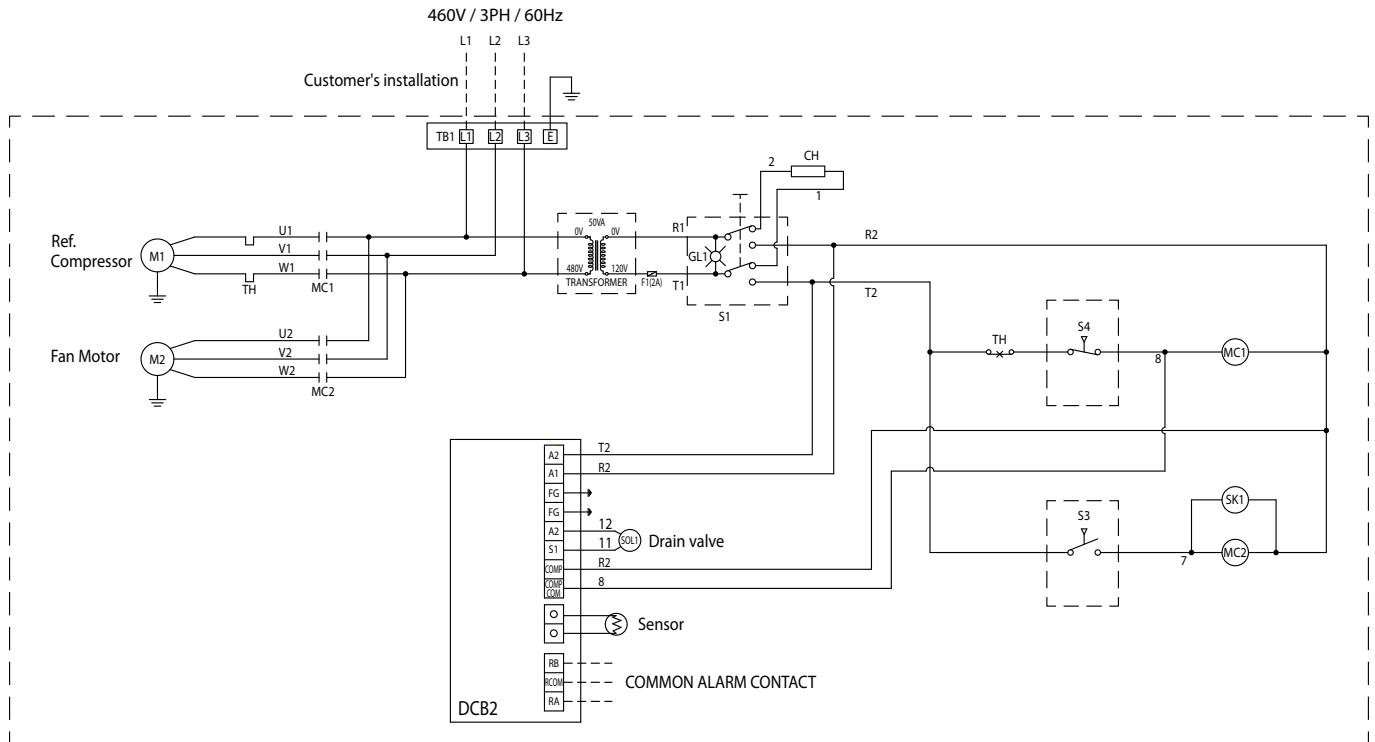

LEGEND

- M1: Refrigerant Compressor
- M2: Fan Motor
- MC1: Magnetic Contactor for Compressor
- MC2: Magnetic Contactor for Fan Motor
- S1: Switch "On-Off"
- TH: Thermal Relay
- S3: Fan Pressure Switch
- S4: High Pressure Switch
- GL1: Green Lamp
- SENSOR: Temperature Sensor
- SOL1: Electronic Drain
- DCB: Digital Control Board
- SK1: Spark Killer, Suppressor
(Resistance: 120Ω + Capacitor: 0.1uF)
- TB1: Terminal Block for Main Power
- CH: Crankcase Heater

SPECIFICATIONS: AIR-COOLED UNITS

Electrical Schematic:
Models HGEN800A through HGEN1200A

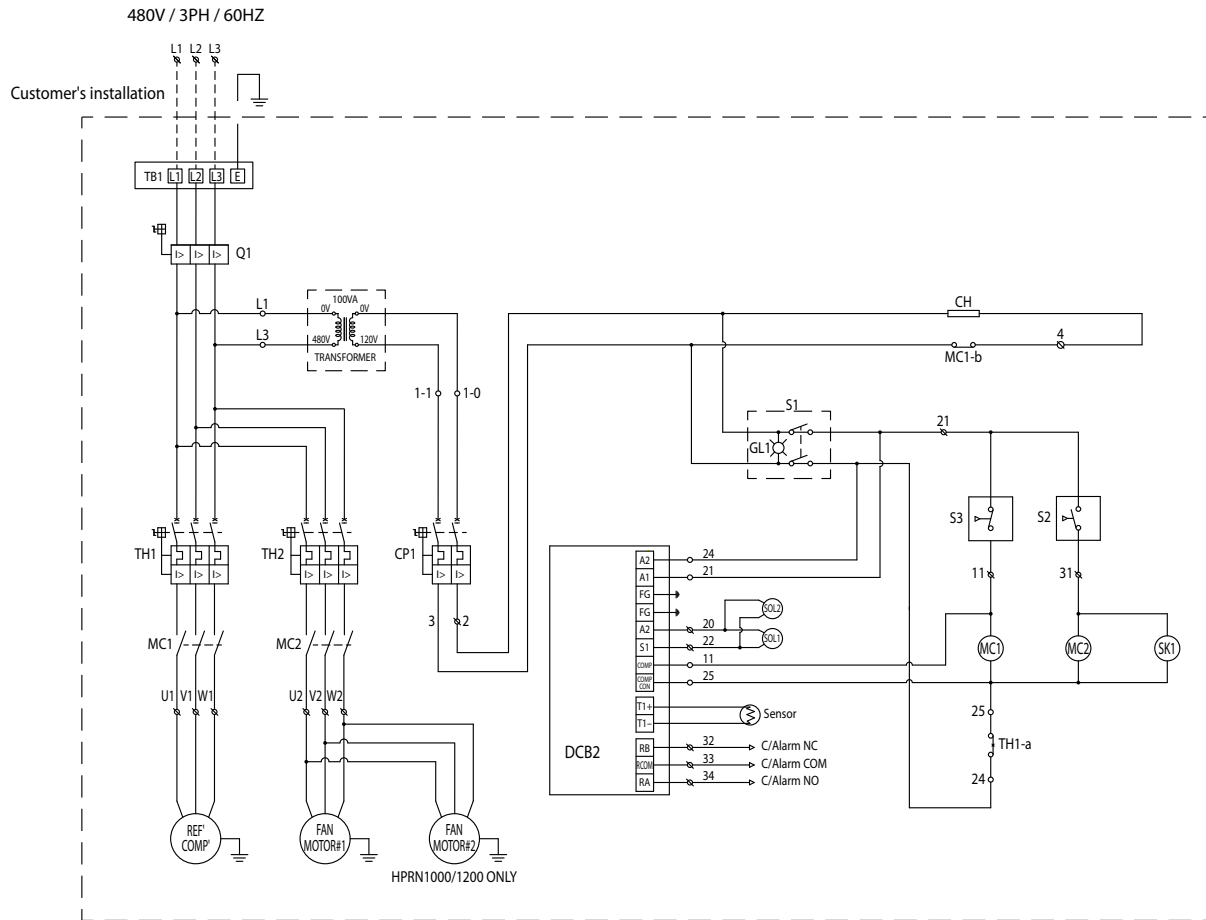

LEGEND

- Q1: Power Cut-Off Switch with Handle
- TH1: Manual Motor Starter for Refrigerant Compressor
- TH2: Manual Motor Starter for Fan Motor
- MC1: Magnetic Contactor for Refrigerant Compressor
- MC2: Magnetic Contactor for Fan Motor
- CP1: Circuit Protector for Control Power
- S1: Switch "On-Off"
- S2: Fan Pressure Switch
- S3: High Pressure Switch
- GL1: Green Lamp
- SOL1: Electronic Drain Valve #1
- SOL2: Electronic Drain Valve #2
- SENSOR: Temperature Sensor
- DCB2: Digital Control Board II
- TB1: Terminal Block for Main Power
- CH: Crankcase Heater

SPECIFICATIONS: AIR-COOLED UNITS

Air and Refrigerant Flow Schematic:
Model HGEN600A

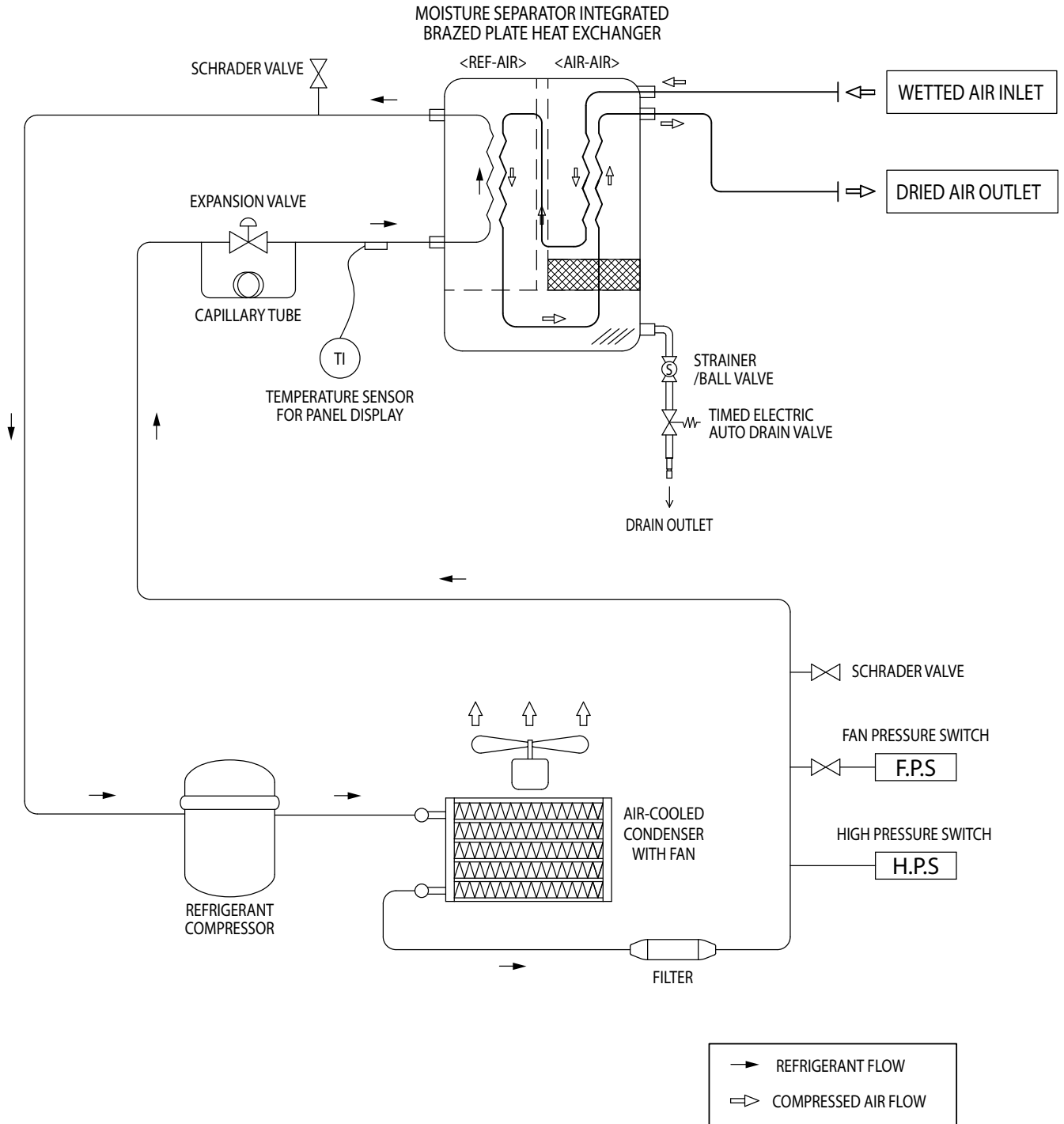

SPECIFICATIONS: AIR-COOLED UNITS

Air and Refrigerant Flow Schematic:
Models HGEN800A through HGEN1200A

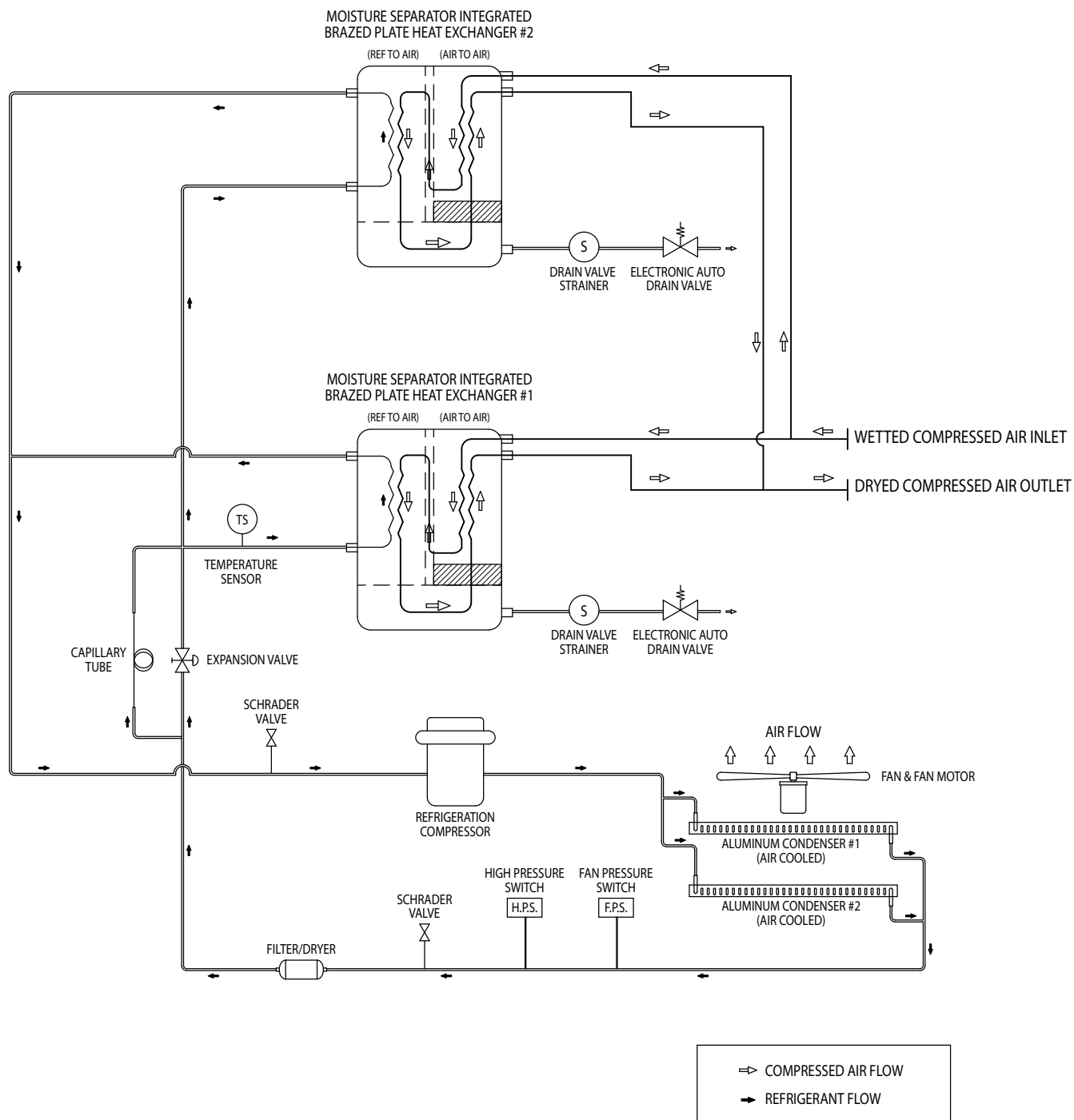

SPECIFICATIONS: WATER-COOLED UNITS

General Arrangement Drawing:
Model HGEN600W

MODEL	DIMENSIONS, INCHES (MM)														INLET/OUTLET CONNECTIONS	COOLING WATER INLET/OUTLET CONNECTIONS	WEIGHT Lb. (kg)
	A	B	C	D	E	F	G	H	J	K	L	M	N	O			
HGEN600W	31.94 (811.2)	21.75 (552.4)	50.44 (1281.3)	4.86 (123.5)	7.94 (201.6)	3.23 (82)	26.74 (679.2)	20.24 (514)	4.18 (106.2)	40.94 (1040)	49.26 (1251.2)	4.52 (114.8)	9.84 (250)	1.97 (50)	2" NPT	3/4" NPT	358 (162)

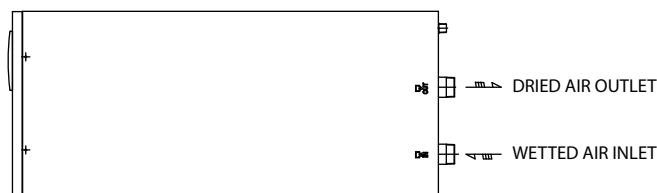

TOP VIEW

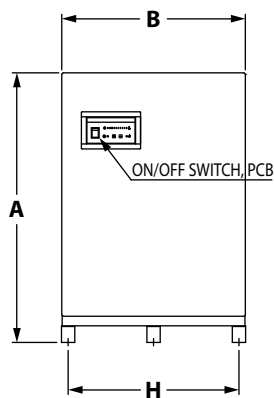

FRONT VIEW

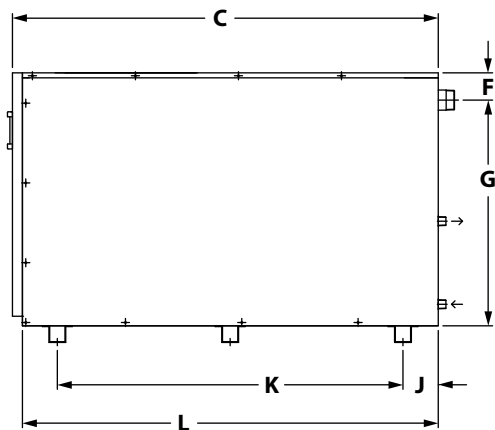

RIGHT SIDE VIEW

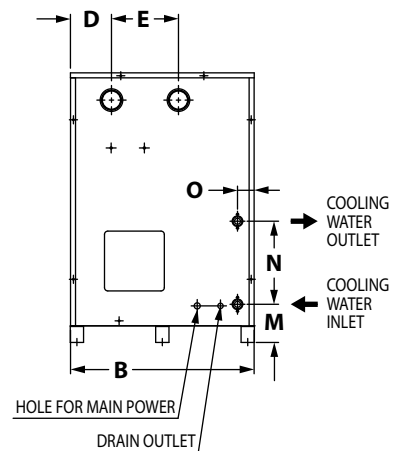

REAR VIEW

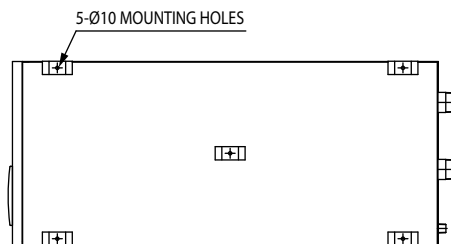

FOOT PRINT

SPECIFICATIONS: WATER-COOLED UNITS

General Arrangement Drawing:
Model HGEN800W

MODEL	DIMENSIONS, INCHES (MM)														INLET/OUTLET CONNECTIONS	COOLING WATER INLET/OUTLET CONNECTIONS	WEIGHT Lb. (kg)
	A	B	C	D	E	F	G	H	J	K	L	M	N	O			
HGEN800W	31.10 (790)	21.10 (536)	10.00 (254)	26.77 (680)	28.35 (720)	37.40 (950)	41.34 (1050)	41.34 (1050)	35.22 (894.5)	6.12 (155.5)	3.35 (85)	6.40 (162.5)	9.84 (250)	1.97 (50)	3" ANSI Flange	3/4" NPT	534 (242)

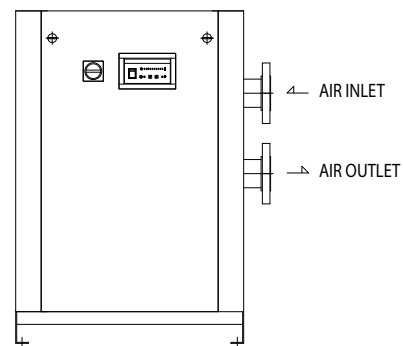
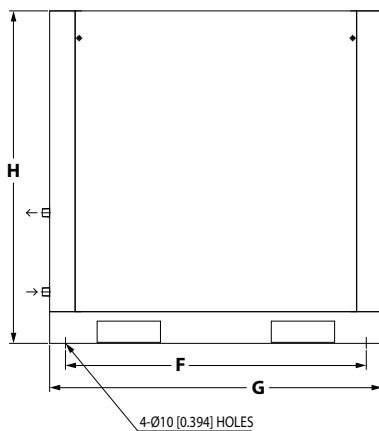
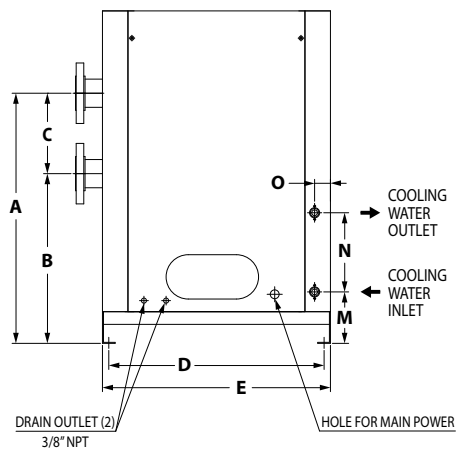
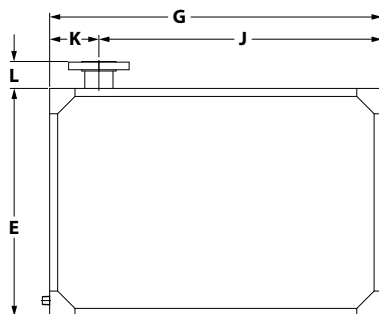

SPECIFICATIONS: WATER-COOLED UNITS

General Arrangement Drawing:
Models HGEN1000W through HGEN1200W

MODEL	DIMENSIONS, INCHES (MM)														INLET/OUTLET CONNECTIONS	COOLING WATER INLET/OUTLET CONNECTIONS	WEIGHT Lb. (kg)
	A	B	C	D	E	F	G	H	J	K	L	M	N	O			
HGEN1000W	31.60 (802.7)	20.60 (523.3)	11.00 (279.4)	26.77 (680)	28.35 (720)	41.34 (1050)	45.28 (1150)	41.34 (1050)	38.68 (982.5)	6.59 (167.5)	3.35 (85)	6.40 (162.5)	9.84 (250)	1.97 (50)	4" ANSI Flange	1" NPT	582 (264)
HGEN1200W	31.60 (802.7)	20.60 (523.3)	11.00 (279.4)	26.77 (680)	28.35 (720)	41.34 (1050)	45.28 (1150)	41.34 (1050)	38.68 (982.5)	6.59 (167.5)	3.35 (85)	6.40 (162.5)	9.84 (250)	1.97 (50)	4" ANSI Flange	1" NPT	626 (284)

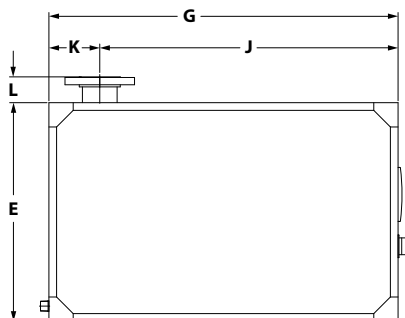

TOP VIEW

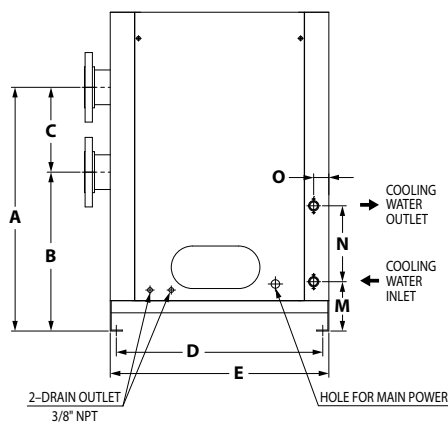

REAR VIEW

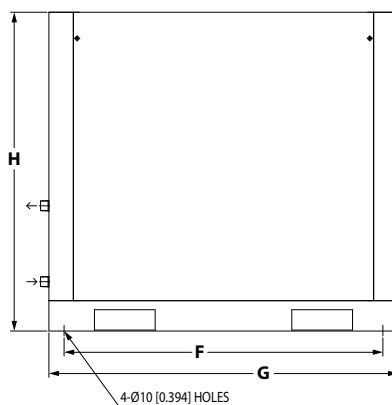

LEFT SIDE VIEW

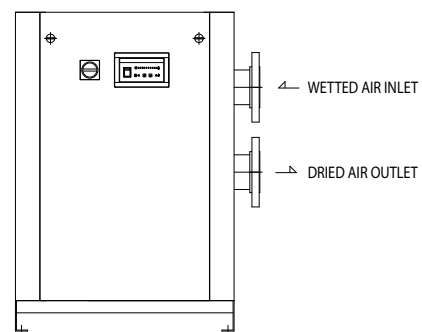

FRONT VIEW

SPECIFICATIONS: WATER-COOLED UNITS

Electrical Schematic:
Model HGEN600W

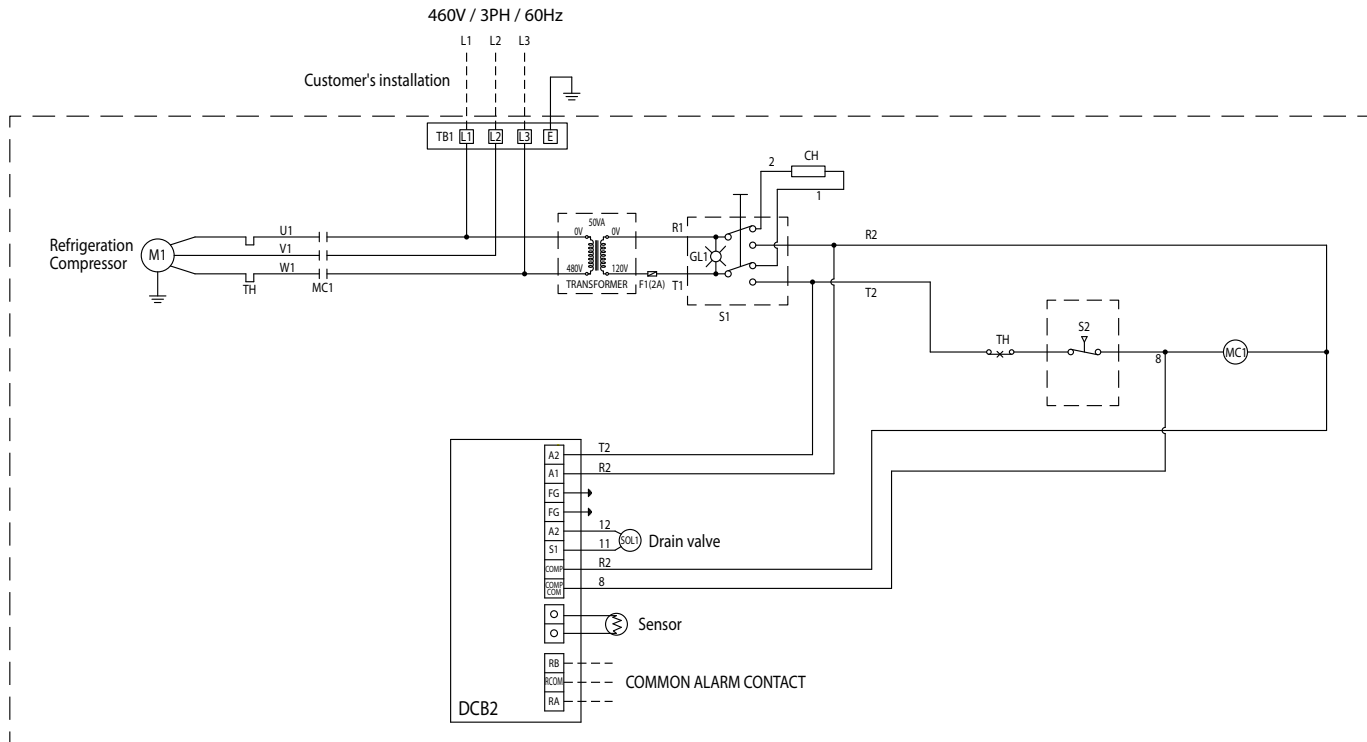

LEGEND

- M1: Refrigerant Compressor
- MC1: Magnetic Contactor
- S1: Switch "On-Off"
- TH: Thermal Relay
- S2: High Pressure Switch
- GL1: Green Lamp
- SENSOR: Temperature Sensor
- SOL1: Electronic Drain
- DCB: Digital Control Board
- TB1: Terminal Block for Main Power
- CH: Crankcase Heater

SPECIFICATIONS: WATER-COOLED UNITS

Electrical Schematic:
Models HGEN800W through HGEN1200W

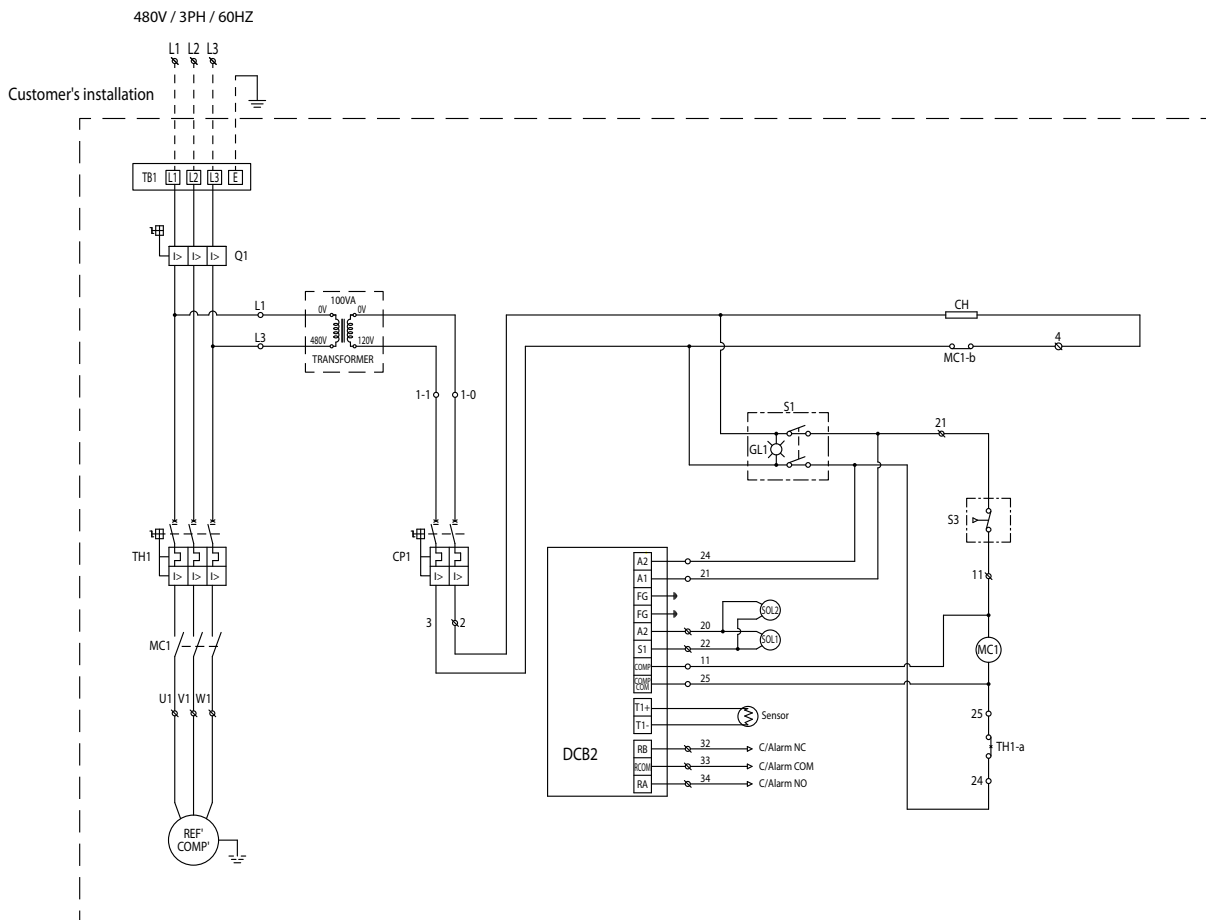

LEGEND

- Q1: Power Cut-Off Switch with Handle
- TH1: Manual Motor Starter for Refrigerant Compressor
- MC1: Magnetic Contactor for Refrigerant Compressor
- CP1: Circuit Protector for Control Power
- S1: Switch "On-Off"
- S2: High Pressure Switch
- GL1: Green Lamp
- SOL1: Electronic Drain Valve #1
- SOL2: Electronic Drain Valve #2
- SENSOR: Temperature Sensor
- DCB2: Digital Control Board II
- TB1: Terminal Block for Main Power
- CH: Cranks case Heater

SPECIFICATIONS: WATER-COOLED UNITS

Air and Refrigerant Flow Schematic:
Model HGEN600W

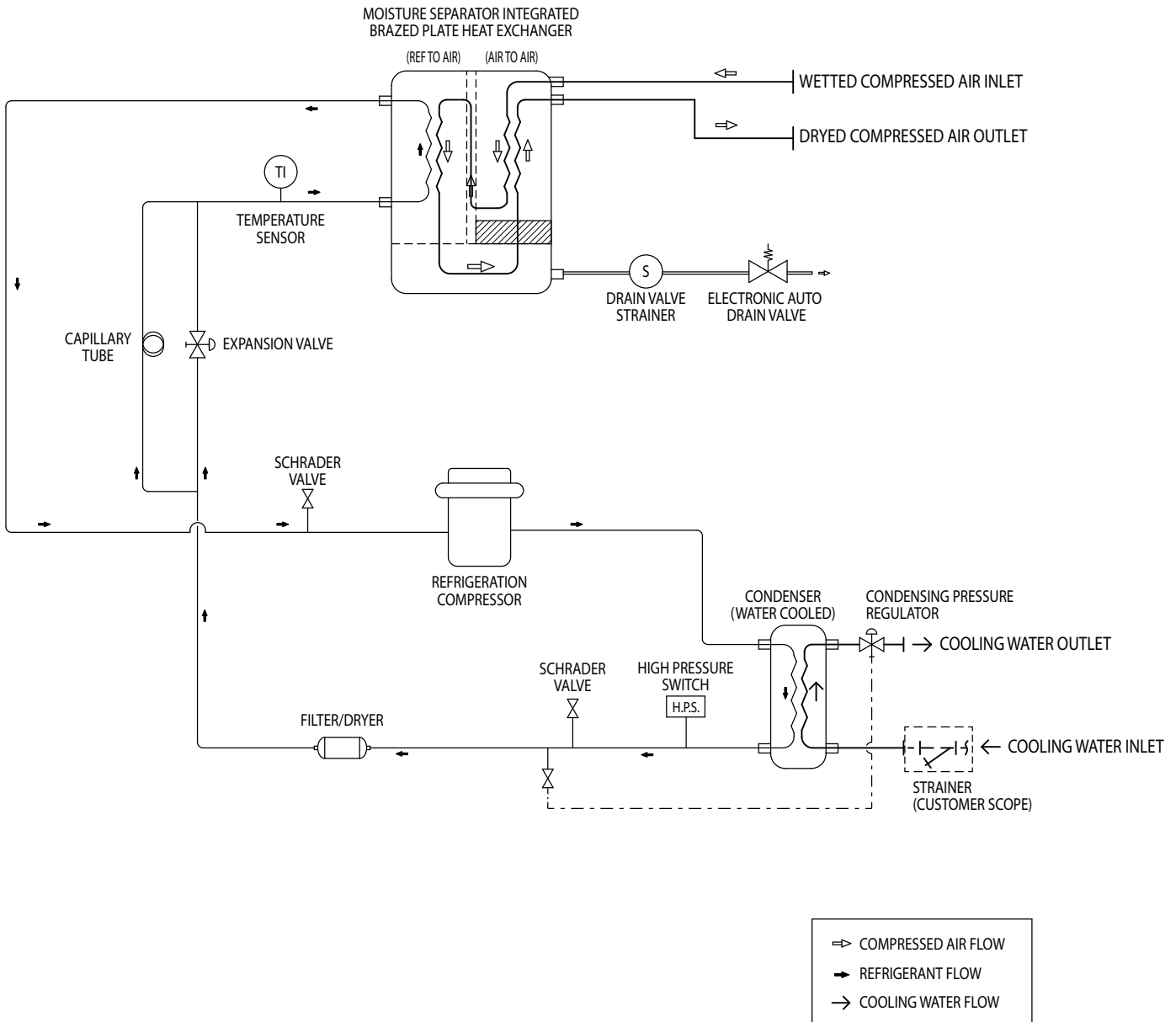

SPECIFICATIONS: WATER-COOLED UNITS

Air and Refrigerant Flow Schematic:
 Models HGEN800W through HGEN1200W

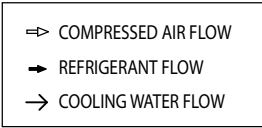
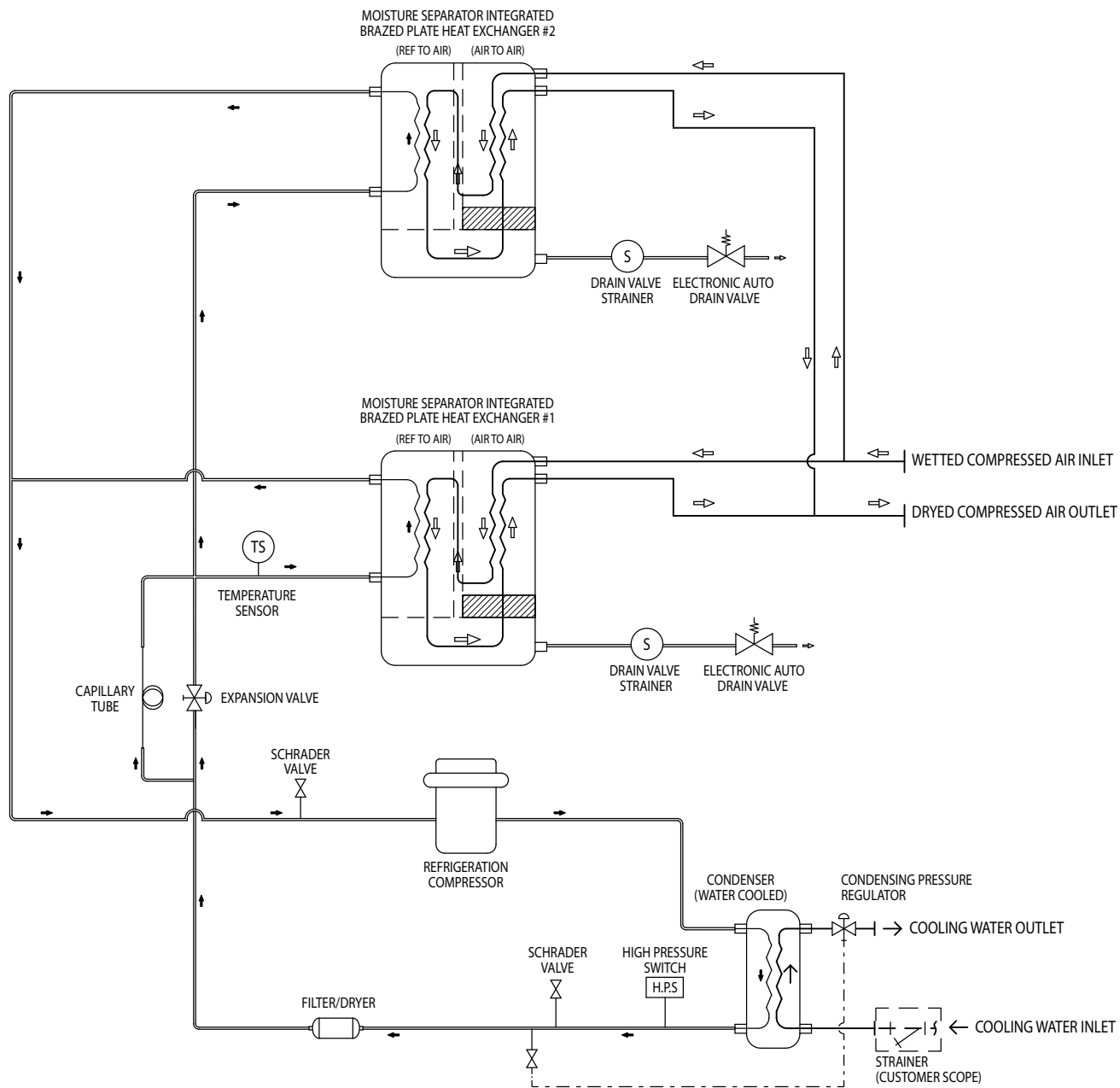

REPLACEMENT PARTS

Item	Description	HGEN600	HGEN800	HGEN1000	HGEN1200	Qty./Unit
1	Heat Exchanger	7439953	—	—	—	1
–	Heat Exchanger	—	7439954	7439955	7439956	2
2	Refrigerant Compressor	7439957	7439958	7439959	7439960	1
3	Constant Pressure Valve	3154841	3154841	3154841	3154841	1
4	Filter Dryer	7439961	7439962	7439962	7439962	1
5	On/Off Switch with Running Lamp	7439963	7439964	7439964	7439964	1
6	Solenoid Valve Assembly	3161248	—	—	—	1
–	Solenoid Valve Assembly	—	3161248	3161248	3161248	2
7	Solenoid Valve Strainer	3146976	—	—	—	1
–	Solenoid Valve Strainer	—	3146976	3146976	3146976	2
8	Dryer System Monitor (DSM)	7433688	7433688	7433688	7433688	1
9	Temperature Sensor	5003174	5003174	5003174	5003174	1
10	Transformer	7439965	7439966	7439966	7439966	1
11	Power Cut off (Disconnect) Switch	—	7439989	7439989	7439989	1
12	Motor Starter - Compressor	—	7439990	7439990	7439990	1
13	Motor Starter - Fan Motor	7451479	7439991	7439991	7439991	1
14	Contactora - Compressor	3242864	7439992	7439992	7439992	1
15	Contactora - Fan Motor	3242863	7439993	7439993	7439993	1
16	Surpressor (Spark Killer)	7439994	7439994	7439994	7439994	1
17	Circuit Protector	—	7439995	7439995	7439995	1
18	Crankcase Heater	7439996	7439997	7439997	7439997	1

Air-Cooled Units

Item	Description	HGEN600A	HGEN800A	HGEN1000A	HGEN1200A	Qty./Unit
1	Condenser (air-cooled)	7439967	7439968	—	—	1
–	Condenser (air-cooled)	—	—	7439967	7439967	2
2	Fan Motor	7439969	7439970	—	—	1
–	Fan Motor	—	—	7439971	7439971	2
3	Fan Pressure Switch	3146975	3146975	3146975	3146975	1
4	High Pressure Switch	7433678	7433678	7433678	7433678	1
5	Fan Guard	7440000	7440001	7440000	7440000	1

Water-Cooled Units

Item	Description	HGEN600W	HGEN800W	HGEN1000W	HGEN1200W	Qty./Unit
1	Condenser	7439972	7439973	7439974	7439975	1
2	Valve - Water Regulating	7439976	7439976	7439977	7439977	1
3	High Pressure Switch	7439978	7439978	7439978	7439978	1

Phone: +1 724 745 8647
Email: ft.dehydration.order.entry@spxflow.com
Web: www.spxflow.com/deltech

NOTES

NOTES

WARRANTY

The manufacturer warrants the product it manufactures, when properly installed, operated, applied, and maintained in accordance with procedures and recommendations outlined in manufacturer's instruction manuals, will be free from defects in material or workmanship for a period as specified below, provided such defect is discovered and brought to the manufacturer's attention within the aforesaid warranty period.

The manufacturer will repair or replace any product or part determined to be defective by the manufacturer within the warranty period, provided such defect occurred in normal service and not as a result of misuse, abuse, neglect or accident. Normal maintenance items requiring routine replacement are not warranted. The warranty covers parts and labor for the warranty period unless otherwise specified. Repair or replacement shall be made at the factory or the installation site, at the sole discretion of the manufacturer. Although not required for warranty consideration, it is recommended that the manufacture be contacted prior to doing any warranty related service work. This action will provide guidance and instruction on the repair often times authorization to perform the work. NOTE: The manufacture reserves the right to repair, replace in the case of warranty approval or reject the warranty claim once submitted.

Unauthorized service and use of unauthorized or pirated parts voids the warranty and any resulting charges or subsequent claim will not be paid. Products repaired or replaced under warranty shall be warranted for the unexpired portion of the warranty applying to the original product.

The foregoing is the exclusive remedy of any buyer of the manufacturer's product. The maximum damages liability of the manufacturer is the original purchase price of the product or part.

THE FOREGOING WARRANTY IS EXCLUSIVE AND IN LIEU OF ALL OTHER WARRANTIES, WHETHER WRITTEN, ORAL, OR STATUTORY, AND IS EXPRESSLY IN LIEU OF THE IMPLIED WARRANTY OF MERCHANTABILITY AND THE IMPLIED WARRANTY OF FITNESS FOR A PARTICULAR PURPOSE. THE MANUFACTURER SHALL NOT BE LIABLE FOR LOSS OR DAMAGE BY REASON OF STRICT LIABILITY IN TORT OR ITS NEGLIGENCE IN WHATEVER MANNER INCLUDING DESIGN, MANUFACTURE OR INSPECTION OF THE EQUIPMENT OR ITS FAILURE TO DISCOVER, REPORT, REPAIR, OR MODIFY LATENT DEFECTS INHERENT THEREIN. THE MANUFACTURER, HIS REPRESENTATIVE OR DISTRIBUTOR SHALL NOT BE LIABLE FOR LOSS OF USE OF THE PRODUCT OR OTHER INCIDENTAL OR CONSEQUENTIAL COSTS, EXPENSES, OR DAMAGES INCURRED BY THE BUYER, WHETHER ARISING FROM BREACH OF WARRANTY, NEGLIGENCE OR STRICT LIABILITY IN TORT.

Please note that the manufacturer's warranty for this product is intended to cover manufacturing defects and therefore does not cover consumable components (desiccants, filter elements, soft goods, standard maintenance kit wear items, etc.) or components that require periodic user adjustment (expansion valve, hot gas bypass valve or cooling water regulating valve) or calibration (dew point elements/sensors, gauge calibration, etc.)

Warranty Period

Parts and labor for two (2) years from the date of shipment from the factory.

An extended warranty of up to 5 years from the date of purchase may be available for your dryer. Please contact your local distributor for more details of the requirements for activation of warranty extension.

AUTHORIZATION FROM THE SERVICE DEPARTMENT IS NECESSARY BEFORE MATERIAL IS RETURNED TO THE FACTORY OR IN-WARRANTY REPAIRS ARE MADE.

SERVICE DEPARTMENT: (724) 746-1100

HGEN Series

Refrigerated Type Compressed Air Dryers

Models: HGEN600, HGEN800,
HGEN1000, HGEN1200

SPXFLOW[®]

SPX FLOW

4647 S.W. 40th Avenue

Ocala, Florida 34474-5788 U.S.A.

P: (724) 745-8647

F: (724) 745-4967

E: deltech.americas@spxflow.com

www.spxflow.com/deltech

Improvements and research are continuous at SPX FLOW, Inc.

Specifications may change without notice.

ISSUED 10/2018 Form No.: 7426448 Revision: B

COPYRIGHT ©2018 SPX FLOW, Inc.